

Wall smoke damper

OPTONE



OPTONE single shutter – OPTONE double shutter

Regulations concerning wall smoke dampers

The regulation for wall smoke dampers is changing

For over 10 years, the European Union has been gradually implementing the "Construction Products" directive on a product by product basis. Today, it is the turn of wall smoke dampers to be upgraded regarding CE marking. This new regulation will disrupt the habits of stakeholders in the fire protection industry. In particular these changes concern:

- New fire resistance testing and classification methods
- New European vocabulary concerning fire resistance
- New CE certificate, in addition to existing documents (fire test report, report as per standard NF-S-61937-10 and NF certification).

BUT IN TECHNICAL TERMS, WHAT CHANGES AFFECT WALL SMOKE DAMPERS?

The wall smoke damper has had to evolve to satisfy new European regulations, an illustration of the best-selling gate type damper in France:

VANTONE damper
Before marking C €

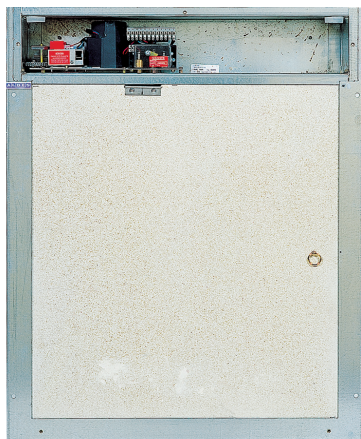

OPTONE damper
After marking C €



Changes in regulations are extensive and impose the full re-qualification of all the ranges:

- test conducted on a European duct compliant with EN1366-8 and/or -9,
- test performed under negative pressure, a damper is placed in the oven to test its ability to remain open at high temperature, another is above the oven, closed, to demonstrate its ability to act as a fire barrier.
- leakage rate minimised to 200 m³/h/m² under the test pressure, either 1000 or 1500 Pa.

CF 1h30 ➡ EI 90 S (Ved - i ↔ o) – 1000 Pa - AA - multi - C300

EXPLANATION OF THE NEW "EUROCLASS" FIRE PROTECTION VOCABULARY:

- **E** = Integrity against fire (corresponds to former Fire Retardant)
- **I** = Insulation (EI corresponds to our former Fire Damper),
- **90** = duration in minutes, or 120 minutes,
- **S** = the leakage rate is stricter at 200 m³/h maximum per m², under test pressure, generally 1000 or 1500 Pa. The S criteria is compulsory in France.
- **i ↔ o** = the damper is tested for internal and external fires, it satisfies restrictions for use as a low position air inlet and high-position wall smoke damper,
- **Ved** = the damper is tested on a vertical duct,
- **1000 Pa**: negative pressure applied to the damper during the fire resistance test: the damper is remote-controlled.
- **multi** as in multi-compartment: the duct is a collective one. Note that the "multi" version is also qualified for use as a "single" duct.
- **C300** = damper reserved for use in a smoke exhaust system. Succeeded a 300-cycle endurance test prior to testing.







HOW TO SELECT A CE MARKED WALL SMOKE DAMPER C €?

- 1 - Ensure the presence of the certificate of CE compliance as per EN 12101-8.
- 2 - Ensure that the damper installation pressure does not exceed the test pressure - indicated on the certificate - in accordance with the decision of 14 March 2011, article 16-d-4 "Only dampers with EIS classification may be used. The installation pressure must not exceed the test pressure."
- 3 - Ensure that the fire classification for the wall smoke damper (EI 90 S or EI 120 S) corresponds to the intended use. Particular attention should be paid to installation. For example, a CE wall smoke damper is always connected to a smoke exhaust duct that is compliant with EN 1366-8 and/or -9 in dimensional terms.

Regulations concerning wall smoke dampers

TABLE OF EQUIVALENCES FOR WALL SMOKE DAMPERS "BEFORE / AFTER CE"

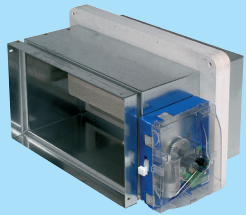
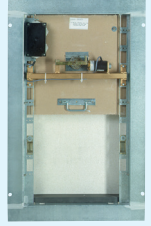
To help you select your new CE-compliant wall smoke damper, we have created this table to indicate correspondences between old and new ranges.

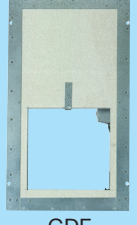
Old dampers	Dampers CE	European vocabulary
 <p>VANTONE PF and CF</p>	 <p>OPTONE " + Grille" OPTONE single shutter OPTONE double shutter</p>	<p>OPTONE " + Grille" EI 90 S - 1000 Pa</p> <p>OPTONE "Classic" EI 90 S - 1000 Pa EI 120 S - 1000 Pa</p>
 <p>VANTONE M</p>	<p>New OPTONE gate type damper</p> <ul style="list-style-type: none"> • OPTONE " + Grille" model offering major time savings on installation and operation. • OPTONE "Classic" model, housing a specific aesthetic grille, type GFE, GGH or GFA 007 in the colour of your choice. 	
 <p>VRFI-DES</p>	 <p>New PLAFONE wall smoke damper</p>	<p>PLAFONE EI 120 S - 1500 Pa</p>
 <p>GCF</p>	 <p>Guillotine wall smoke dampers are no longer produced, use an OPTONE double shutter damper to limit travel in the duct.</p>	<p>OPTONE " + Grille" EI 90 S - 1000 Pa</p> <p>OPTONE "Classic" EI 90 S - 1000 Pa EI 120 S - 1000 Pa</p>
 <p>GDF</p>	<p>The GDF transfer damper is not a wall smoke damper as defined by the standard EN 12101-8, so it has not been modified.</p>	

OPTONE Wall smoke damper

Presentation of the new OPTONE wall smoke damper range

New



Standards compliance

- Compliant with CE marking as per EN 12101-8: 1812 - CPD -1053 and 1055
- EI 90 (ved-i ↔ o) S
1000 Pa - AA multi
- EI 120 (ved-i ↔ o) S
1000 Pa - AA multi
- H > 1000 = EI 60 S
- Certified 

Advantages

- Time savings on installation of OPTONE "+Grille" model.
- Easy wiring.
- Motors on whole range.



INTRODUCTION

Inspired by its counterpart OPTONE.H on sale since early 2012, the new OPTONE gate type wall smoke damper will replace all VANTONE dampers very quickly due to the CE marking requirement as per standard EN 12101-8.

The new range of OPTONE dampers present a new and exclusive design:

OPTONE "+ Grille"

This patented innovation satisfies most installation requirements and saves time by avoiding the installation of the separate grille.

To satisfy certain aesthetic needs, there is also the **OPTONE "Classic"** range, to which GFA 007, GFE or GGH type grilles may be installed.

QUALIFICATION

- Compliant with CE marking as per EN 12101-8: certificate no. pending
- Fire resistance classification according to EN 1366-10 test:
 1. OPTONE "+ Grille":
 - EI 90** (ved-i ↔ o) S - 1000 Pa - AA multi, compliant with § 7.2.4 of EN 13501-4, qualified on Promatect L500 smoke exhaust duct and on ducts compliant with EN 1366-9 made of the same material and with the same density.
 - 2.a OPTONE "Classic":
 - EI 120** (ved-i ↔ o) S - 1000 Pa - AA multi, compliant with § 7.2.4 of EN 13501-4, qualified on Promatect L500 smoke exhaust duct and on ducts compliant with EN 1366-9 made of the same material and with the same density.
 - 2.b OPTONE "Classic" for H > 1000 mm:
 - E 120** (ved-i ↔ o) S - 1000 Pa - AA multi, compliant with § 7.2.4 of EN 13501-4, qualified on Promatect L500 smoke exhaust duct and on ducts compliant with EN 1366-9 made of the same material and with the same density.
- Leakage rate: the OPTONE damper presents a very low leakage rate: under 1000 Pa, the rate is < 200m³/h per m² of shutter surface, or less than 40m³/h under 1000 Pa for a 400 x 650 mm damper.
- Pressure loss lower than VANTONE dampers with equivalent dimensions.

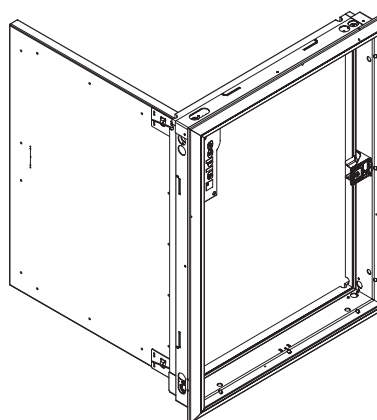

OPTONE "+ Grille" single-shutter – open with blade core removed

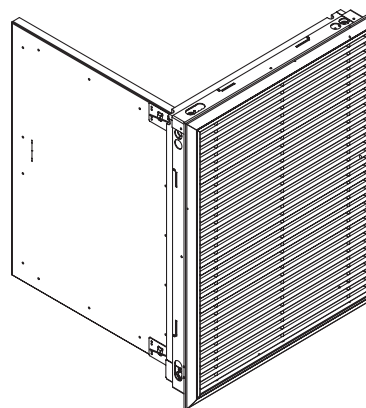

OPTONE "+ Grille" single-shutter – open with blade core

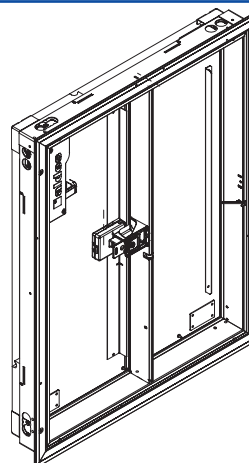

OPTONE "Classic" double-shutter – closed

OPTONE Wall smoke damper

Presentation of the new OPTONE wall smoke damper range

New



Advantages

- Simplicity: Nominal dimensions = embedding dimension
- Reversible mounting frame top/ bottom
- Same mounting frame for all OPTONE models
- Built-in cable passages

DESCRIPTION

- The OPTONE wall smoke damper comprises:
 - an aluminium frame built with sections that are crimped together on the inside to offer first rate exterior aesthetics,
 - a shutter made of refractory material,
 - an electric control mechanism in a protective box.
- The damper is supplied with essential accessories:
 - 20/10 mm thick steel mounting frame, dimensions 12 x 70 mm,
 - choice of aesthetic aluminium grille:
 - on the **OPTONE "+Grille"**, model, the grille frame is combined with into the damper, the blade core is removable with invisible Zamak clips (same principle as on OPTONE.H),
 - GFA 007 grille to fix on front face of **OPTONE "Classic"** damper,
 - GFE or GGH grille to place in front of the **OPTONE "Classic"** damper.
- The nominal L x H dimensions of the damper correspond to the dimensions of the opening required to embed the mounting frame, which is fixed without adhesive mortar.
- Free air passage (dm²) on the damper depends on the L and H (mm) dimensions and the number of shutters:
 - Single shutter = ((L-57) x (H-57) -14147) / 10000
 - Double shutter = ((L-76) x (H-57) -14147) / 10000
- The locking system is positioned on the shutter, in order to enable as much air passage as possible and to reduce pressure losses.
- An airtight seal when cold is provided by 2 elastomer gaskets clipped into the frame grooves:
 - the first seals the frame and the shutter
 - the second seals the frame and the duct.
- An airtight seal when hot is provided by 2 intumescent seals fixed around the outside of the damper facing the blade field and the duct sleeve.
- Electric wiring can be passed through a corner near the control box.
- The locking system features a trip attached to the shutter which slots into a bolt lock embedded in the frame. The electromagnetic trip device is self-resetting, enabling you to close the shutter with just one hand. It is patented.
- The connection box is evolutive and is designed to facilitate electrical connections:
 - screwless terminals for the remote control and motorised reset,
 - detachable signalling contacts
 - large space to house electronic modules for fire safety systems,
 - pre-equipped with electrical connections to enable fitting of reset motor at a late time.

SIZE RANGES AND FREE AIR PASSAGES (dm²)

OPTONE "+Grille" - Single-shutter code 11044410
 OPTONE "Classic" - Double-shutter code 11044420 / OPTONE "Classic" - 2H.single shutter code 11044430

Free air passage (dm ²)	L = width of opening for mounting frame fixed without adhesive mortar									
	300	350	400	450	500	550	600	650	700	
H = height of opening for mounting frame fixed without adhesive mortar	300	4.5	5.7	6.9	8.1	9.4	10.6	11.8	13.0	14.2
	350	5.7	7.2	8.6	10.1	11.6	13.0	14.5	16.0	17.4
	400	6.9	8.6	10.4	12.1	13.8	15.5	17.2	18.9	20.6
	450	8.1	10.1	12.1	14.0	16.0	18.0	19.9	21.9	23.9
	500	9.4	11.6	13.8	16.0	18.2	20.4	22.6	24.9	27.1
	550	10.6	13.0	15.5	18.0	20.4	22.9	25.4	27.8	30.3
	600	11.8	14.5	17.2	19.9	22.6	25.4	28.1	30.8	33.5
	650	13.0	16.0	18.9	21.9	24.9	27.8	30.8	33.8	36.7
	700	14.2	17.4	20.6	23.9	27.1	30.3	33.5	36.7	39.9
	750	15.4	18.9	22.4	25.8	29.3	32.8	36.2	39.7	43.1
800	16.6	20.4	24.1	27.8	31.5	35.2	38.9	42.6	46.4	
850	17.9	21.8	25.8	29.8	33.7	37.7	41.6	45.6	49.6	
900	19.1	23.3	27.5	31.7	35.9	40.1	44.4	48.6	52.8	

OPTONE "+ Grille" double-shutter code 11044411
 OPTONE "Classic" double-shutter code 11044421 / OPTONE "Classic" - 2H. double-shutter code 11044431

Free air passage (dm ²)	L = width of opening for mounting frame fixed without adhesive mortar												
	450	500	550	600	650	700	750	800	850	900	950	1000	
H = height of opening for mounting frame fixed without adhesive mortar	300	7.7	8.9	10.1	11.3	12.5	13.7	15.0	16.2	17.4	18.6	19.8	21.0
	350	9.5	11.0	12.5	13.9	15.4	16.9	18.3	19.8	21.3	22.7	24.2	25.7
	400	11.4	13.1	14.8	16.6	18.3	20.0	21.7	23.4	25.1	26.8	28.6	30.3
	450	13.3	15.2	17.2	19.2	21.1	23.1	25.1	27.0	29.0	31.0	32.9	34.9
	500	15.2	17.4	19.6	21.8	24.0	26.2	28.4	30.7	32.9	35.1	37.3	39.5
	550	17.0	19.5	22.0	24.4	26.9	29.3	31.8	34.3	36.7	39.2	41.7	44.1
	600	18.9	21.6	24.3	27.0	29.8	32.5	35.2	37.9	40.6	43.3	46.0	48.8
	650	20.8	23.7	26.7	29.7	32.6	35.6	38.6	41.5	44.5	47.4	50.4	53.4
	700	22.6	25.8	29.1	32.3	35.5	38.7	41.9	45.1	48.4	51.6	54.8	58.0
	750	24.5	28.0	31.4	34.9	38.4	41.8	45.3	48.8	52.2	55.7	59.2	62.6
	800	26.4	30.1	33.8	37.5	41.2	44.9	48.7	52.4	56.1	59.8	63.5	67.2
	850	28.2	32.2	36.2	40.1	44.1	48.1	52.0	56.0	60.0	63.9	67.9	71.9
	900	30.1	34.3	38.5	42.8	47.0	51.2	55.4	59.6	63.8	68.0	72.3	76.5
	950	32.0	36.4	40.9	45.4	49.8	54.3	58.8	63.2	67.7	72.2	76.6	81.1
	1000	33.9	38.6	43.3	48.0	52.7	57.4	62.1	66.9	71.6	76.3	81.0	85.7
1050	35.7	40.7	45.7	50.6	55.6	60.5	65.5	70.5	75.4	80.4	85.4	90.3	
1100	37.6	42.8	48.0	53.2	58.5	63.7	68.9	74.1	79.3	84.5	89.7	95.0	
1150	39.5	44.9	50.4	55.9	61.3	66.8	72.3	77.7	83.2	88.6	94.1	99.6	
1200	41.3	47.0	52.8	58.5	64.2	69.9	75.6	81.3	87.1	92.8	98.5	104.2	

For heights H > 1000, the damper only exists in the "Classic" version and is qualified EI 60 (ved-i ↔ o) S 1000 Pa.

OPTIONS

The shutter may feature a galvanised steel trim to offer uniform aesthetics and protect the wiring from the public and prevent vandalism. The trim may be painted with the RAL color of your choice.

OPTONE Wall smoke damper

Presentation of mounting frame for OPTONE wall smoke damper

New

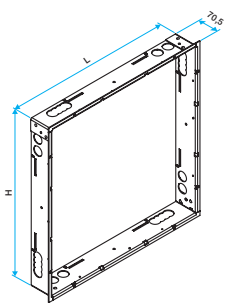

Standards compliance

- The mounting frame is mandatory to respect the fire resistance classification.

Advantages

- Simplicity: Nominal dimensions = embedding dimension
- Reversible mounting frame top/bottom
- Same mounting frame for all OPTONE models
- Built-in cable passages

INSTALLATION

The mounting frame is an indispensable accessory that ensures the wall smoke damper is installed correctly. It not only offers a good base for the installation work, the damper can be mounted and removed easily throughout the life of the building.

The OPTONE mounting frame is reversible, so ensure the width and height dimensions are correctly respected.

The same mounting frame can be used for both the OPTONE "+ Grille" model and the OPTONE "Classic" model, and also for single-shutter or double-shutter versions.

The mounting frame is selected simply on the basis of the nominal width x height dimensions.

The OPTONE mounting frame is designed to be fixed by screws or using mortar.

- To seal in place using mortar, unfold the four anchor tabs before positioning the mounting frame in the duct.
- To attach with screws, use the holes other than any marked a or b.

The OPTONE wall smoke damper requires the passage of electric cables, so the instructions on the label should be respected.

This label is affixed to each mounting frame.

RANGE

Designation	Code
OPTONE mounting frame L x H	11044406

DIMENSIONS OF MOUNTING FRAME (mm)

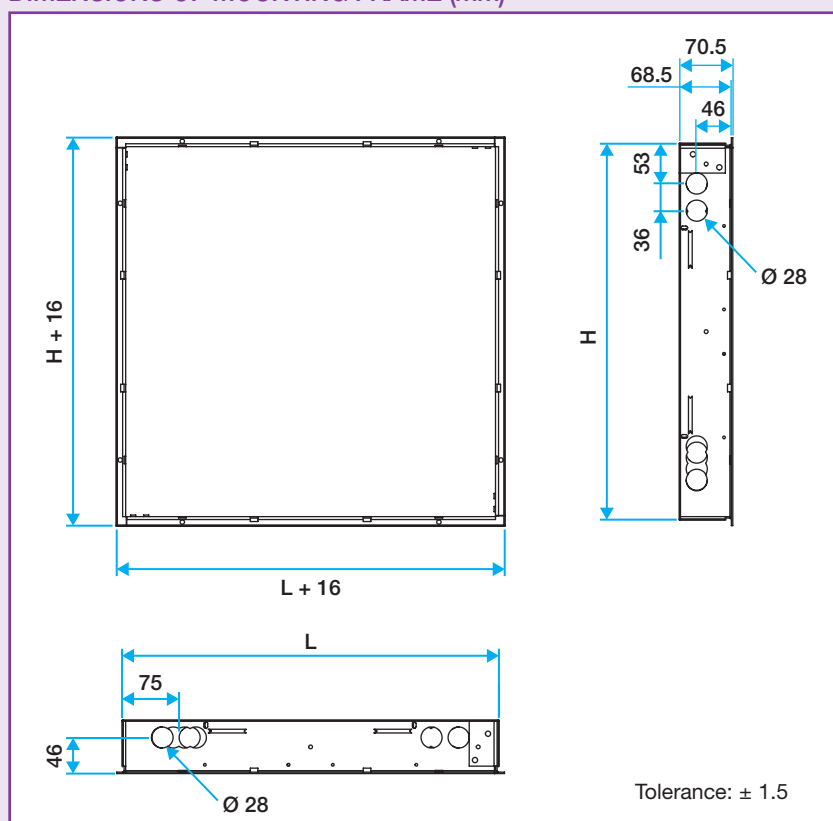

MARKING ON MOUNTING FRAME

- Cable entrance with mechanism in high position, left opening
- Cable entrance with mechanism in low position, right opening
- Possible entrance conditional on prior drilling

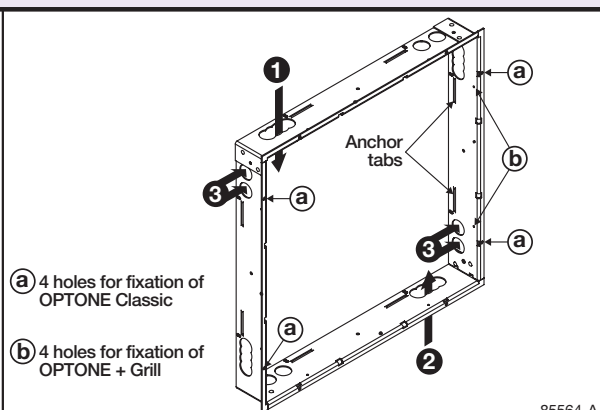

aldes

Advice for cable entrances

NEVER COUNTER-DRILL THE HOLES IN THE MOUNTING FRAME

OPTONE Wall smoke damper

Installation instructions for OPTONE wall smoke dampers

New

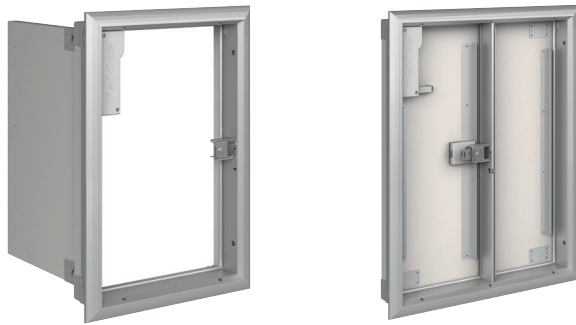

Advantages

- Simplicity: Nominal dimensions = embedding dimension

For the air passage for the high position damper to be at least 1.80 m from the ground in accordance with standard IT 246 for ceilings ≤ 2700 mm in height, position the mounting frame at a minimum height of 1.77m.

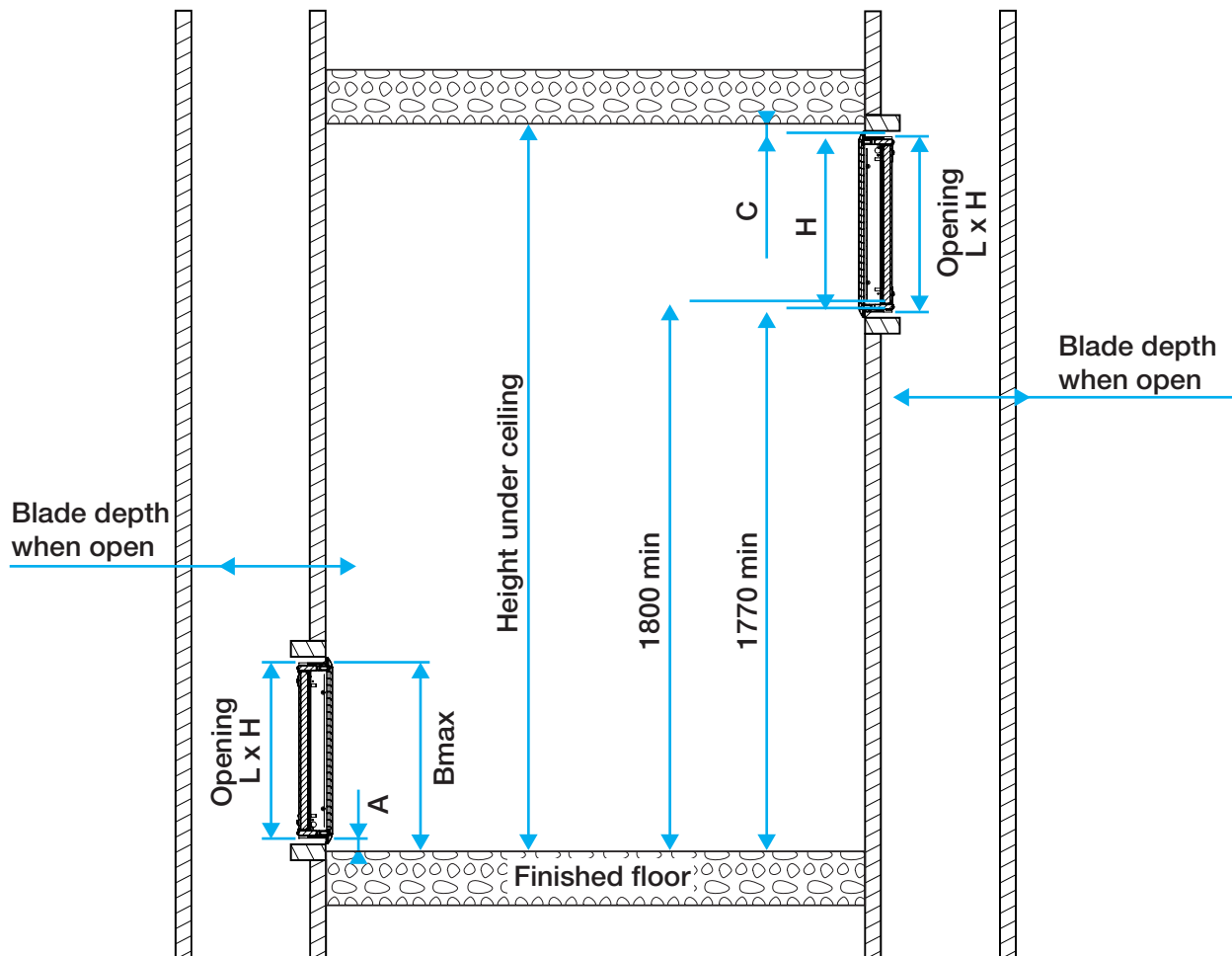

$C = 22$ mm for OPTONE +Grille
 $C = 32$ mm for OPTONE Classic with GFA 007
 $A =$ plinth height +c
 $B_{max} = A + H < 1030$

For light materials such as Promatect, Supalux or Tecriver, the mounting frame is screwed into a peripheral sleeve.

OPTONE Wall smoke damper

New OPTONE "+ Grille" smoke damper

New



OPTONE "+ Grille"
without blade core



OPTONE "+ Grille"
with blade core

Standards compliance

- Compliant with CE marking as per EN 12101-8: 1812 - CPD -1053
- EI 90 (ved-i → o) S
1000 Pa - AA multi
- EI 60 S for H > 100

Advantages

- Simplicity: Nominal dimensions = embedding dimension
- Reversible mounting frame top/ bottom
- Same mounting frame for all OPTONE models
- Built-in cable passages
- All dampers can be motorised

RANGE

Designation	Code	EI S
OPTONE "+ Grille" 1 shutter	11044410	90
OPTONE "+ Grille" 2 shutters	11044411	90

INSTALLATION

For which installation?

- Qualified on a Promatect L500 smoke exhaust duct and on ducts compliant with EN 1366-9 of the same material and same density.
- The "multi-compartment" wall smoke dampers are suitable for "single-compartment" applications.
- The fire classification mentions the installation pressure: the damper must not work with pressures > -1000 Pa.
- Fire direction: as all wall exhaust dampers, respect fire inside the smoke exhaust duct (when the damper is closed).

How?

- The CONCEPTOR DESENFUMAGE smoke damper selection software may help you to define the embedding dimensions for the mounting frame so as to comply with Technical Instruction 246 (IT 246). The detailed installation instructions will be of great help to ensure correct installation of the dampers on your site.
- The nominal L x H dimensions of the damper correspond to the dimensions of the opening required to embed the mounting frame, without travel. To install a mortar-sealed mounting frame, add the desired thickness of the mortar to the L x H dimensions.
- The OPTONE damper is reversible:
 - box on upper left = cable passage on upper left + left opening for single shutter versions,
 - box on lower right = cable passage on lower right + right opening for single shutter versions.

What fixing method to use?

- Embedded in a vertical smoke exhaust duct.
- The mounting frame is fixed in a duct sleeve with a minimum length of 110 mm, attached with 8 VBA screws $\varnothing 5 \times 70$ mm (not supplied).
- The damper is fixed in place using four self-tapping screws supplied.
- The screws are driven into the lugs on the aluminium frame, which purposely buckle under the force applied.

MAIN DIMENSIONS

- Overall dimensions for single- or double shutter = L + 43 x H + 43 mm.
- Blade depth when open, single-shutter = L + 30 mm.
- Blade depth when open, double-shutter = L/2 + 70 mm.

OPTONE "+ GRILLE" DIMENSIONS (mm)

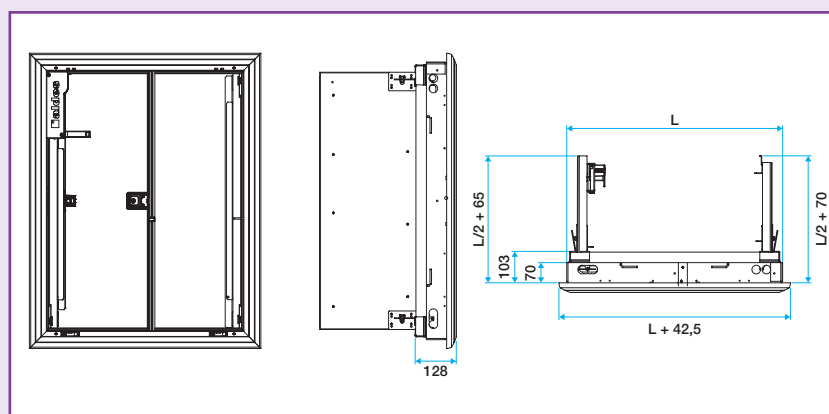
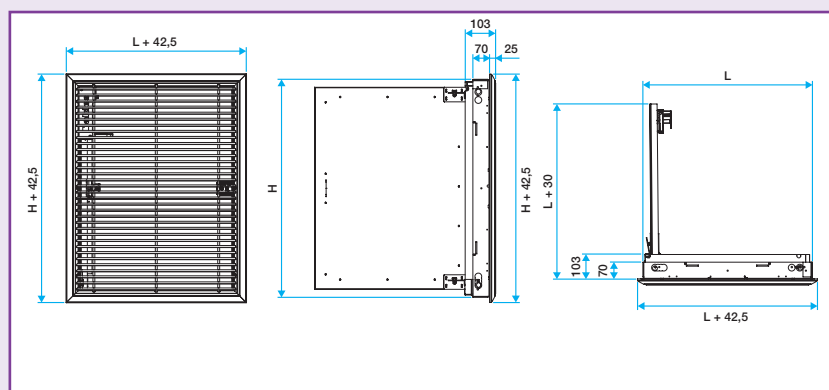
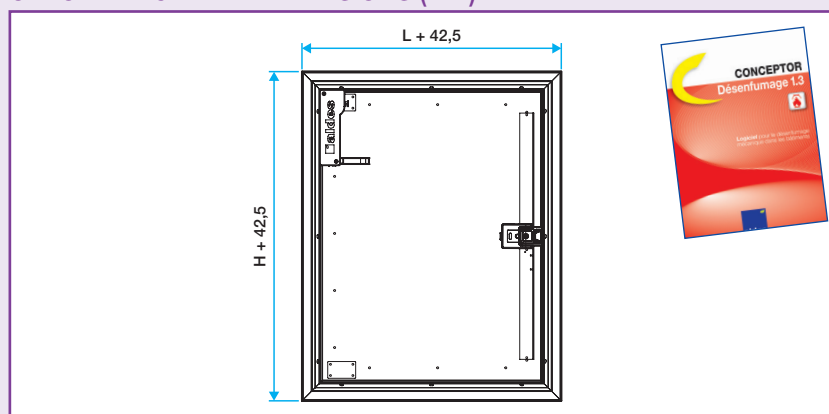

OPTONE Wall smoke damper

New OPTONE "Classic" smoke damper

New

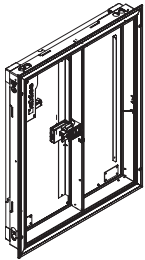

OPTONE "Classic"

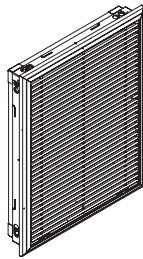

OPTONE "Classic" fitted with GFA 007 grille

Standards compliance

- Compliant with CE marking as per EN 12101-8: 1812 - CPD -1055
- EI 90 (ved-i ↔ o) S
1000 Pa - AA multi
- EI 120 (ved-i ↔ o) S
1000 Pa - AA multi
- EI 60 S for H > 1000

Advantages

- Simplicity: Nominal dimensions = embedding dimension
- Reversible mounting frame top/bottom
- Same mounting frame for all OPTONE models
- Built-in cable passages
- All dampers can be motorised

RANGE

Designation	Code	EI S
OPTONE "Classic" 1 shutter	11044420	90
OPTONE "Classic" 2 shutter	11044421	90
OPTONE "Classic" 2 H/1 shutter	11044430	120
OPTONE "Classic" 2 H/2 shutter	11044431	120

INSTALLATION

For which installation?

- Qualified on a Promatect L500 smoke exhaust duct and on ducts compliant with EN 1366-9 of the same material and same density.
- The "multi-compartment" wall smoke dampers are suitable for "single-compartment" applications.
- The fire classification mentions the installation pressure: the damper must not be subjected to pressures > -1000 Pa.
- Fire direction: as all wall smoke dampers, respect fire inside the wall smoke duct (when the damper is closed).

How?

- The CONCEPTOR DESENFUMAGE smoke damper selection software may help you to define the embedding dimensions for the mounting frame so as to comply with Technical Instruction 246 (IT 246). The detailed installation instructions will be of great help to ensure correct installation of the dampers on your site.
- The nominal L x H dimensions of the damper correspond to the dimensions of the opening required to embed the mounting frame, without travel. To install a mortar-sealed mounting frame, add the desired thickness of the mortar to the L x H dimensions.
- The OPTONE damper is reversible:
 - box on upper left = cable passage on upper left + left opening for single shutter versions,
 - box on lower right = cable passage on lower right + right opening for single shutter versions.

What fixing method to use?

- Embedded in a vertical smoke exhaust duct.
- The mounting frame is fixed in a duct sleeve with a minimum length of 110 mm, attached with 8 VBA screws Ø 5 x 70 mm (not supplied).
- The damper is fixed in place using four self-tapping screws supplied.
- Fixed on the front face using the drilled holes in the mounting frame.

MAIN DIMENSIONS

- Overall dimensions with GFA 007 grille = L +56 x H +63 mm.
- Blade depth when open, single-shutter = L +30 mm.
- Blade depth when open, double-shutter = L/2 +70 mm.

DESCRIPTION OF OPTONE GFA 007

- The OPTONE "Classic" damper can be fitted with a GFA 007 grille that has all the same characteristics as the GFA 007 on the old VANTONE dampers.
- Code 11044408 GFA 007 OPTONE "Classic" can be fixed to either single-shutter or double-shutter dampers using the 4 inserts located on the front of the OPTONE damper.

OPTONE "CLASSIC" DIMENSIONS (mm)

