

## POWER & EFFICIENCY

INPUT POWER OPTIONS	AC 1PH 200-240V 60Hz   AC 3PH 200-240V 60Hz   AC 3PH 380-480V 60Hz		
MAXIMUM RATED CURRENT (amp)	5.4-4.5 A		2.8-2.4 A   2.2-1.9 A
POWER (hp)	3/4 hp		
MAXIMUM SPEED (RPM)	105 RPM		

## DIMENSIONS & WEIGHT

FAN DIAMETER	14 ft
FAN WEIGHT	168 lb (76 kg)

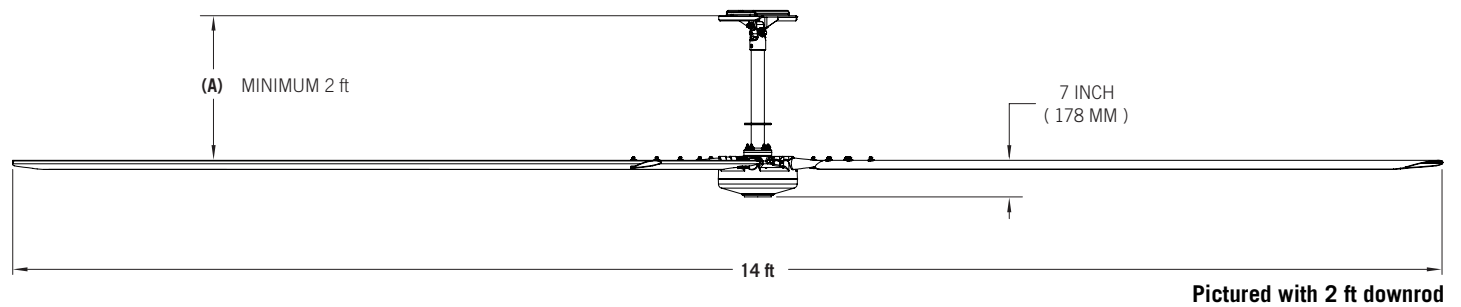

## MOUNTING & SAFETY

MOUNTING OPTIONS	I-beam   Glulam
DOWNROD (A)	Downrods available in 1 ft increments: 2 ft min., 10 ft max. Downrod length must be specified at time of order.
SAFETY FEATURES	Fan Retention System   Airfoil Retention System   Fire relay

## IN THE BOX

INCLUDED	Fan I-beam mount with pre-wired downrod   Control panel   Install manual Mounting hardware kit   Communication Kit   Guy wire kit
OPTIONAL	Additional cable lengths   Touchscreen (5 in)   Glulam brackets

## WARRANTY & CERTIFICATIONS

CERTIFICATIONS	ETL/Intertek-certified to ANSI/UL 507 and CSA C22.2 No. 113 in North America
WARRANTY <sup>1</sup>	15-year, Non-Prorated Warranty

<sup>1</sup>See complete warranty for details.

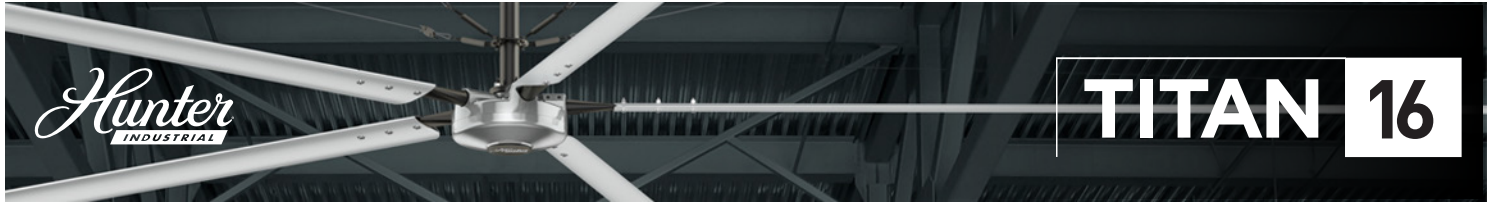

## POWER & EFFICIENCY

INPUT POWER OPTIONS	AC 1PH 200-240V 60Hz   AC 3PH 200-240V 60Hz   AC 3PH 380-480V 60Hz		
MAXIMUM RATED CURRENT (amp)	7.2-6 A		3.8-3.2 A   3.1-2.6 A
POWER (hp)	1 hp		
MAXIMUM SPEED (RPM)	102 RPM		

## DIMENSIONS & WEIGHT

FAN DIAMETER	16 ft
FAN WEIGHT	175 lb (79 kg)

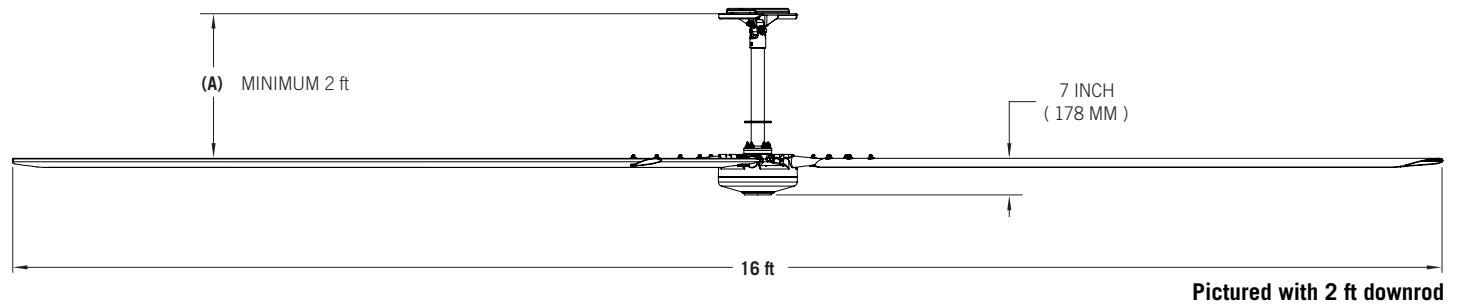

## MOUNTING & SAFETY

MOUNTING OPTIONS	I-beam   Glulam
DOWNROD (A)	Downrods available in 1 ft increments: 2 ft min., 10 ft max. Downrod length must be specified at time of order.
SAFETY FEATURES	Fan Retention System   Airfoil Retention System   Fire relay

## IN THE BOX

INCLUDED	Fan I-beam mount with pre-wired downrod   Control panel   Install manual Mounting hardware kit   Communication Kit   Guy wire kit
OPTIONAL	Additional cable lengths   Touchscreen (5 in)   Glulam brackets

## WARRANTY & CERTIFICATIONS

CERTIFICATIONS	ETL/Intertek-certified to ANSI/UL 507 and CSA C22.2 No. 113 in North America
WARRANTY <sup>1</sup>	15-year, Non-Prorated Warranty

<sup>1</sup>See complete warranty for details.

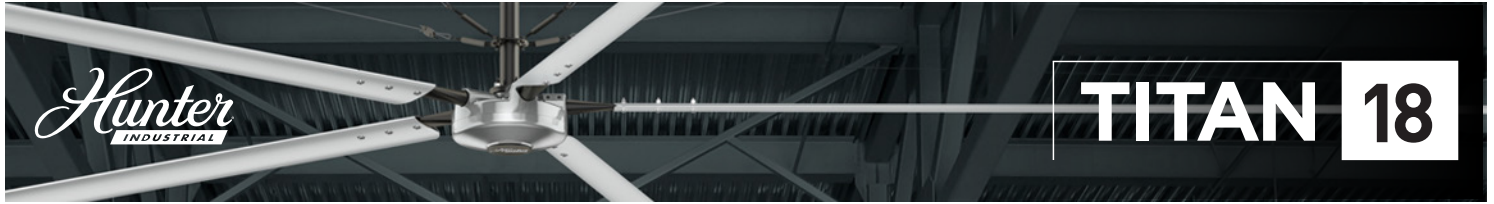

## POWER & EFFICIENCY

INPUT POWER OPTIONS	AC 1PH 200-240V 60Hz   AC 3PH 200-240V 60Hz   AC 3PH 380-480V 60Hz		
MAXIMUM RATED CURRENT (amp)	7.8-6.5 A		4.1-3.4 A   3.3-2.7 A
POWER (hp)	1 hp		
MAXIMUM SPEED (RPM)	95 RPM		

## DIMENSIONS & WEIGHT

FAN DIAMETER	18 ft
FAN WEIGHT	183 lb (83 kg)

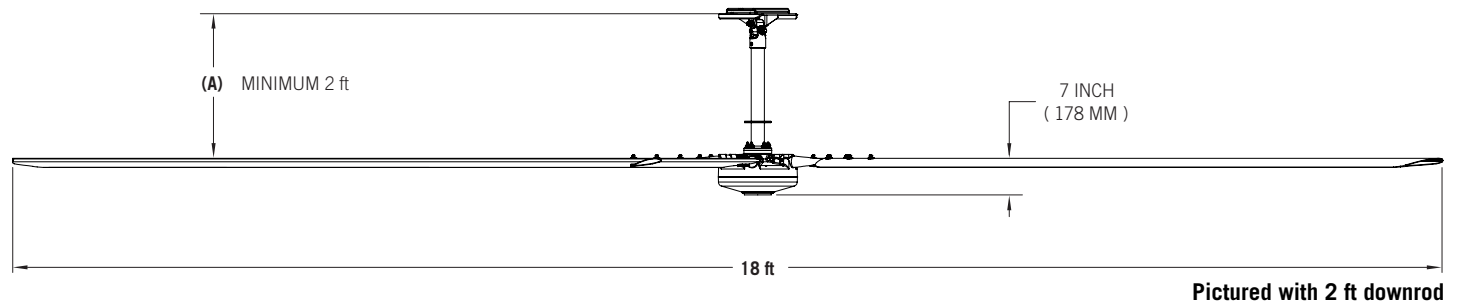

## MOUNTING & SAFETY

MOUNTING OPTIONS	I-beam   Glulam
DOWNROD (A)	Downrods available in 1 ft increments: 2 ft min., 10 ft max. Downrod length must be specified at time of order.
SAFETY FEATURES	Fan Retention System   Airfoil Retention System   Fire relay

## IN THE BOX

INCLUDED	Fan I-beam mount with pre-wired downrod   Control panel   Install manual Mounting hardware kit   Communication Kit   Guy wire kit
OPTIONAL	Additional cable lengths   Touchscreen (5 in)   Glulam brackets

## WARRANTY & CERTIFICATIONS

CERTIFICATIONS	ETL/Intertek-certified to ANSI/UL 507 and CSA C22.2 No. 113 in North America
WARRANTY <sup>1</sup>	15-year, Non-Prorated Warranty

<sup>1</sup>See complete warranty for details.

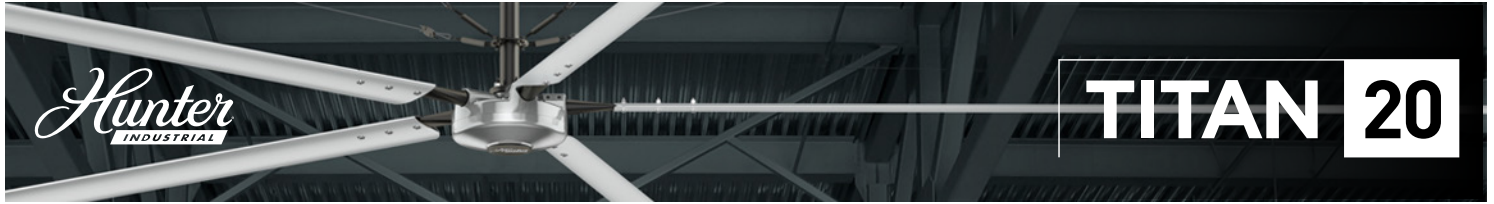

## POWER & EFFICIENCY

INPUT POWER OPTIONS	AC 1PH 200-240V 60Hz   AC 3PH 200-240V 60Hz   AC 3PH 380-480V 60Hz		
MAXIMUM RATED CURRENT (amp)	7.2-6 A		4-3.3 A   3.0-2.5 A
POWER (hp)	1 hp		
MAXIMUM SPEED (RPM)	82 RPM		

## DIMENSIONS & WEIGHT

FAN DIAMETER	20 ft
FAN WEIGHT	190 lb (86 kg)

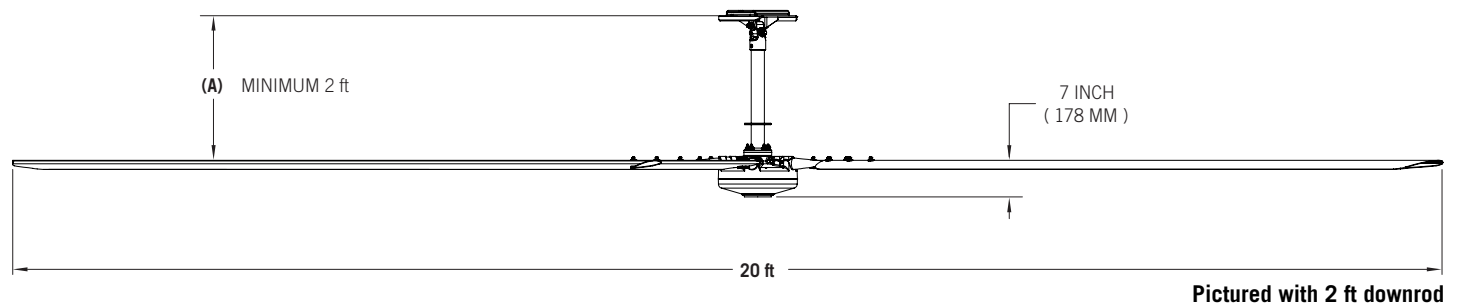

## MOUNTING & SAFETY

MOUNTING OPTIONS	I-beam   Glulam
DOWNROD (A)	Downrods available in 1 ft increments: 2 ft min., 10 ft max. Downrod length must be specified at time of order.
SAFETY FEATURES	Fan Retention System   Airfoil Retention System   Fire relay

## IN THE BOX

INCLUDED	Fan I-beam mount with pre-wired downrod   Control panel   Install manual Mounting hardware kit   Communication Kit   Guy wire kit
OPTIONAL	Additional cable lengths   Touchscreen (5 in)   Glulam brackets

## WARRANTY & CERTIFICATIONS

CERTIFICATIONS	ETL/Intertek-certified to ANSI/UL 507 and CSA C22.2 No. 113 in North America
WARRANTY <sup>1</sup>	15-year, Non-Prorated Warranty

<sup>1</sup>See complete warranty for details.

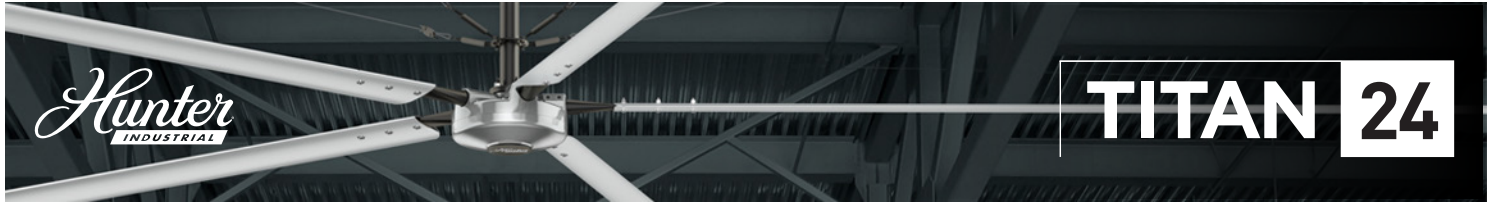

## POWER & EFFICIENCY

INPUT POWER OPTIONS	AC 1PH 200-240V 60Hz   AC 3PH 200-240V 60Hz   AC 3PH 380-480V 60Hz		
MAXIMUM RATED CURRENT (amp)	8.2-6.8 A	4.3-3.6 A	3.2-2.7 A
POWER (hp)	1 hp		
MAXIMUM SPEED (RPM)	70 RPM		

## DIMENSIONS & WEIGHT

FAN DIAMETER	24 ft
FAN WEIGHT	204 lb (93 kg)

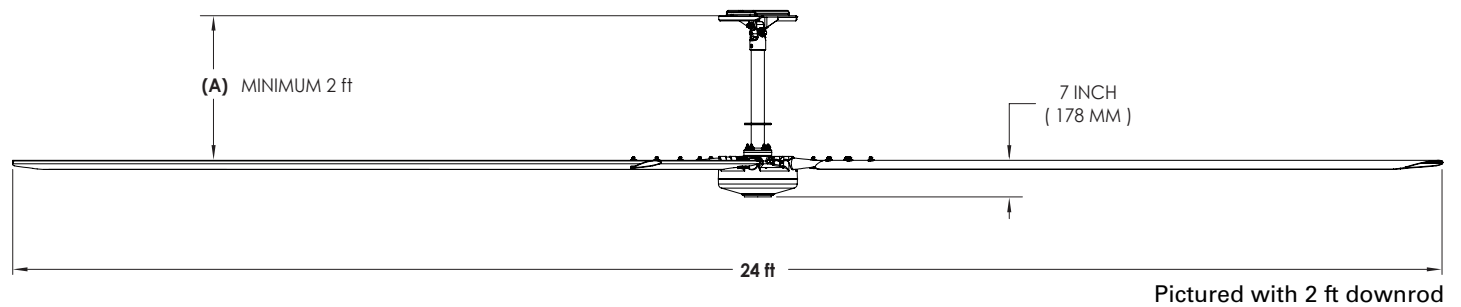

## MOUNTING & SAFETY

MOUNTING OPTIONS	I-beam   Glulam
DOWNROD (A)	Downrods available in 1 ft increments: 2 ft min., 10 ft max. Downrod length must be specified at time of order.
SAFETY FEATURES	Fan Retention System   Airfoil Retention System   Fire relay

## IN THE BOX

INCLUDED	Fan I-beam mount with pre-wired downrod   Control panel   Install manual Mounting hardware kit   Communication Kit   Guy wire kit
OPTIONAL	Additional cable lengths   Touchscreen (5 in)   Glulam brackets

## WARRANTY & CERTIFICATIONS

CERTIFICATIONS	ETL/Intertek-certified to ANSI/UL 507 and CSA C22.2 No. 113 in North America
WARRANTY <sup>1</sup>	15-year, Non-Prorated Warranty

<sup>1</sup>See complete warranty for details.